

Classic Wood Narrow High Table

ASSEMBLY INSTRUCTIONS

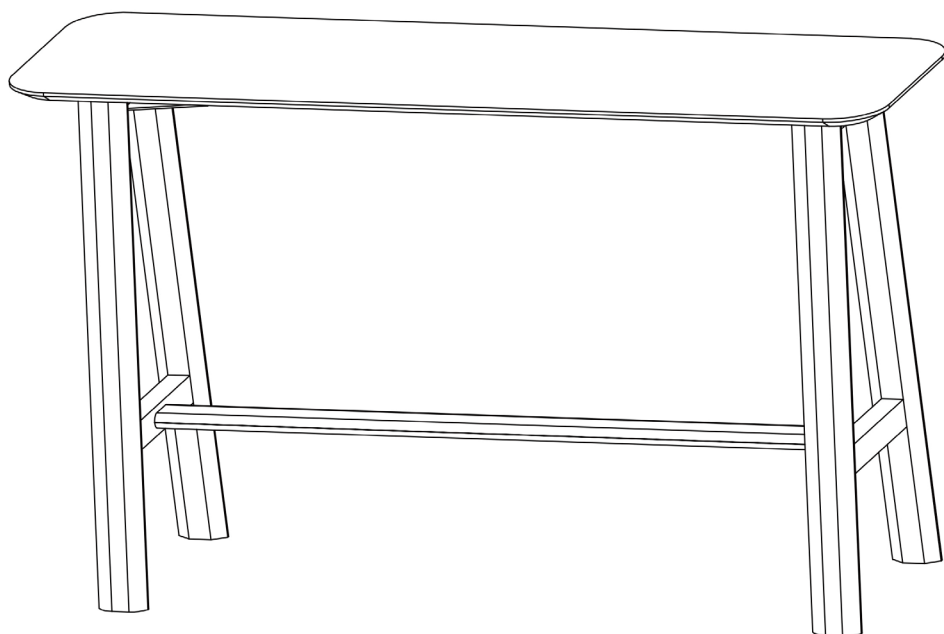

FRIANT

Natural warmth, elevated form.

Tools



(included)

Allen Key
5mm

1 pc

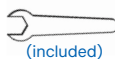

(included)

Wrench
13mm

1 pc



(not-included)

Phillips
Head





1 pc

Online
Assembly
Video



Components

Hardware

A		M8 25mm	10 pcs	E		Semicircular Connector	2 pcs
B		M8 110mm	2 pcs	F		Washer	2 pcs
C		M5 40mm	8 pcs				
D		M8	2 pcs				

Main Parts

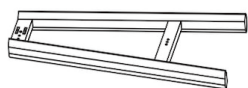

G
Leg Frame
2 pcs



H
Work Top
1 pc



I
Foot Rail
1 pc



J
Beam
1 pc

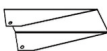

K
Bracket Cover
2 pcs



L
Bracket
2 pcs

1

Let's start with the frame. Grab the Beam (J), one Leg Frame (G), and one Semicircular Connector (E). Insert the Semicircular Connector (E) into the circular hole at the end of the Beam (J), aligning the hole in the connector with the hole on the beam. Then move to the leg. Insert one (B) stud into the middle hole of the Leg Frame (G)—the one between the two notches—and tighten securely.

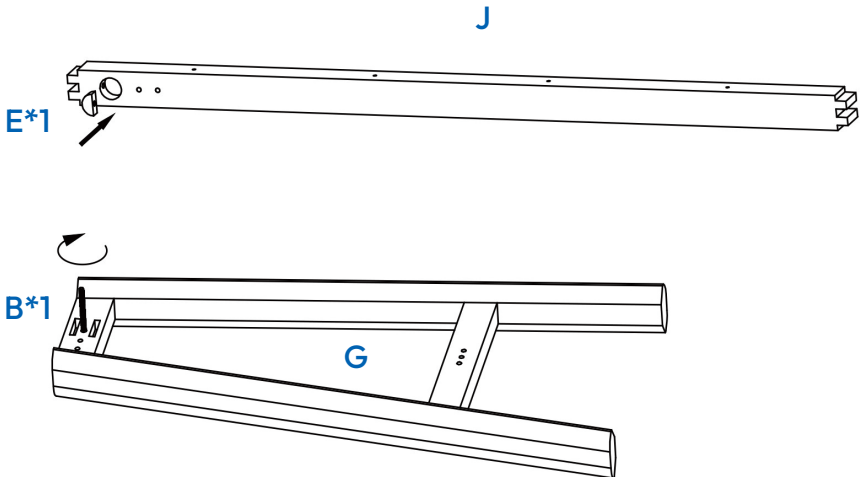

2

Place the Leg Frame (G) on the ground with the stud facing up. Align the Beam (J) with the notches on the inner side of the Leg Frame (G). Insert the stud (B) through the hole in the beam until both parts fit securely together.

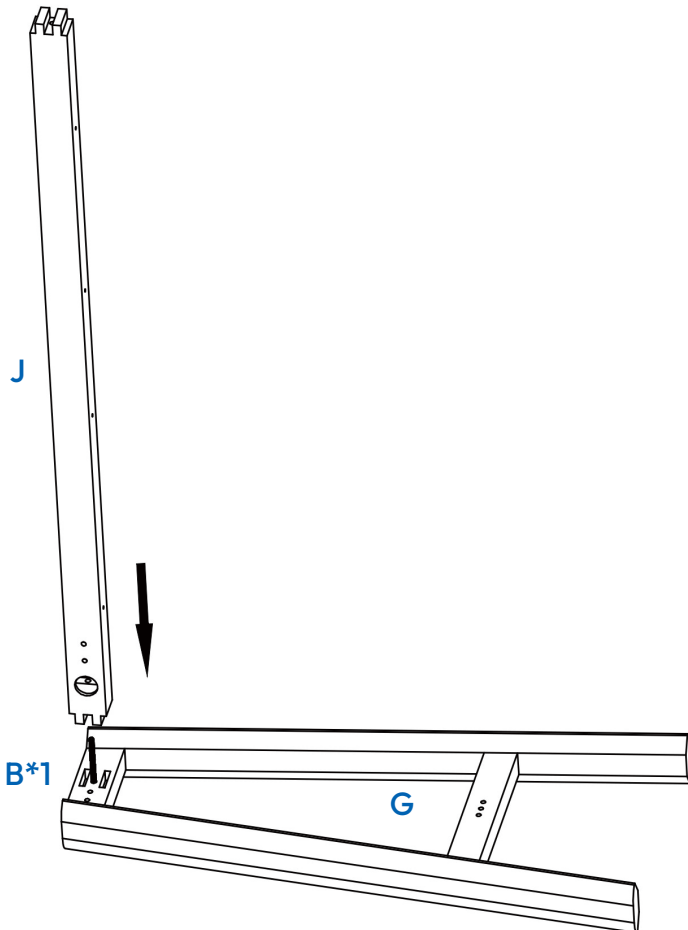

3

Grab one Nut (D) and one Washer (F) as a pair.
Use a 13mm wrench to fasten them onto the stud
by turning clockwise.

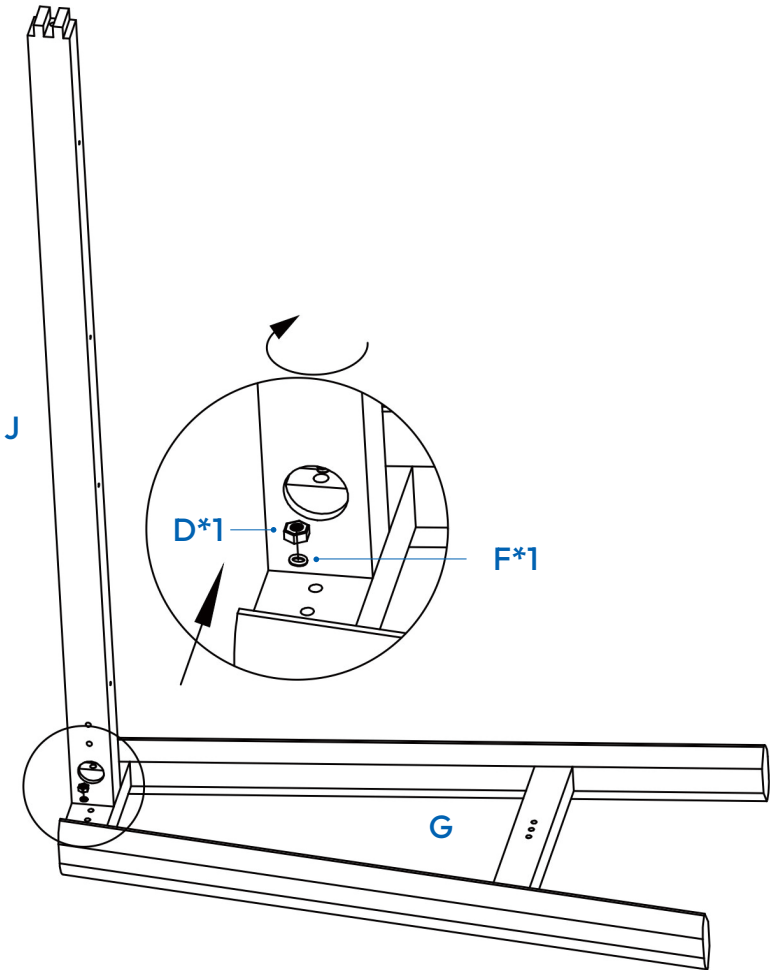

4

Take one Bracket (L) and use four (A) screws to secure the Bracket (L) to the Beam (J) and Leg Frame (G). Tighten securely.

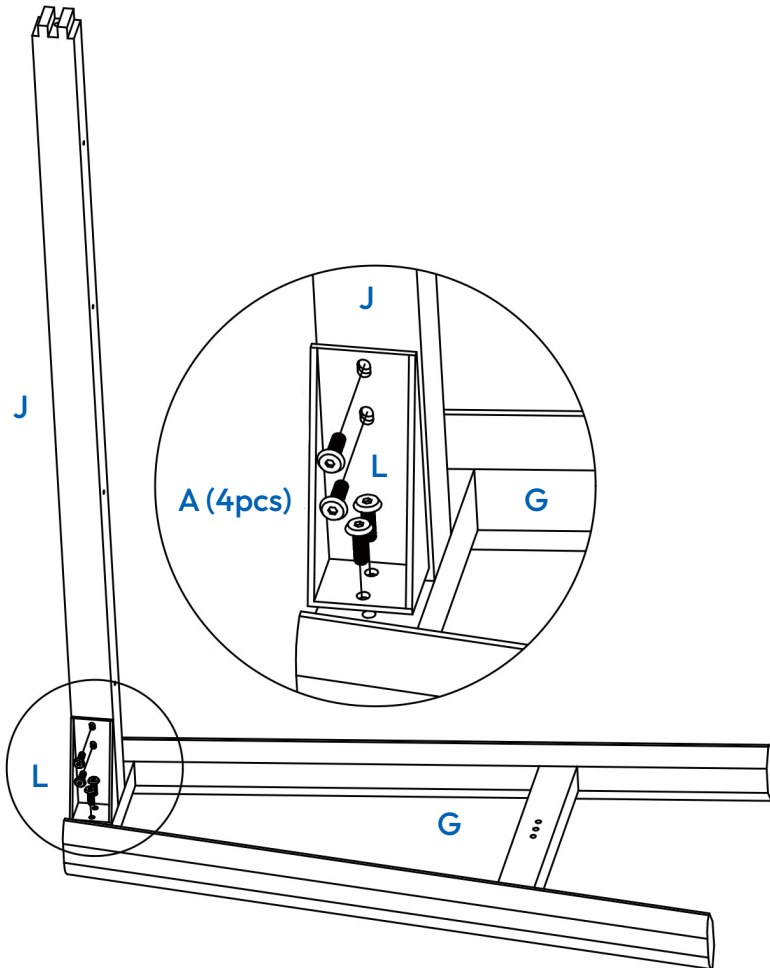

5

Take the other Semicircular Connector (E) and repeat the installation process on the opposite end of the Beam (J).

Then grab the Foot Rail (I), align its protruding parts with the holes on the base support of the Leg Frame (G). Remove the small cover on the foot rail and use one (A) screw to fasten it securely.

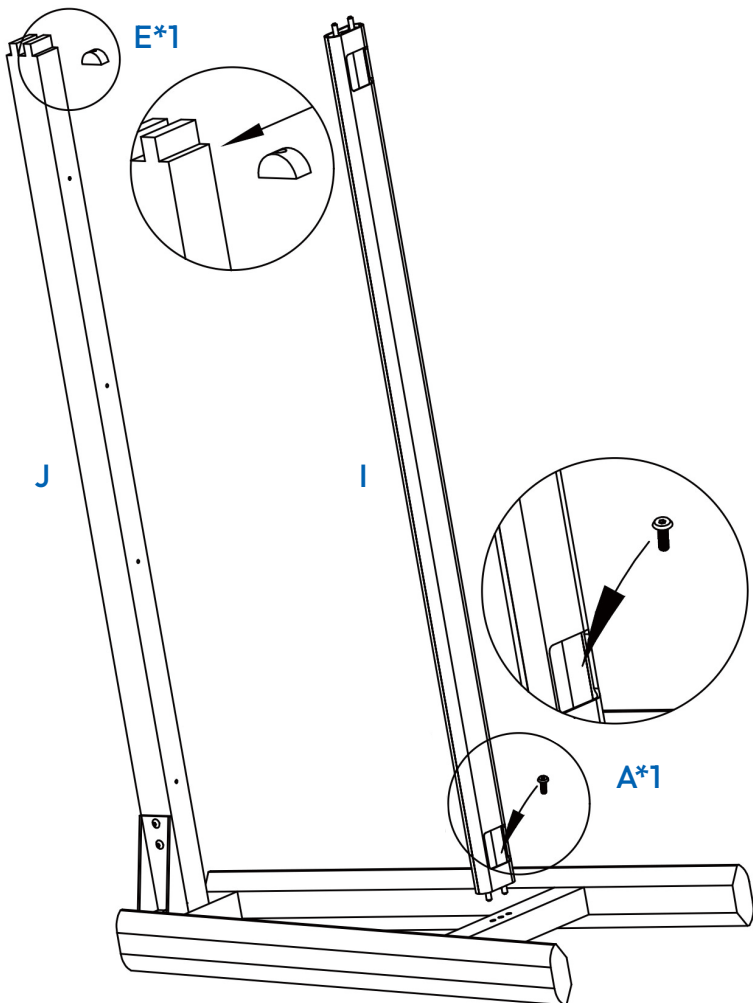

6

Bring the other Leg Frame (G) over and lift the half assembled frame upright. For the beam, repeat the previous installation process (Step 1, 2, 3), using one Nut (D), one Washer (F), and one (B) stud to fasten the frame securely. Then connect the foot rail with one (A) screw.

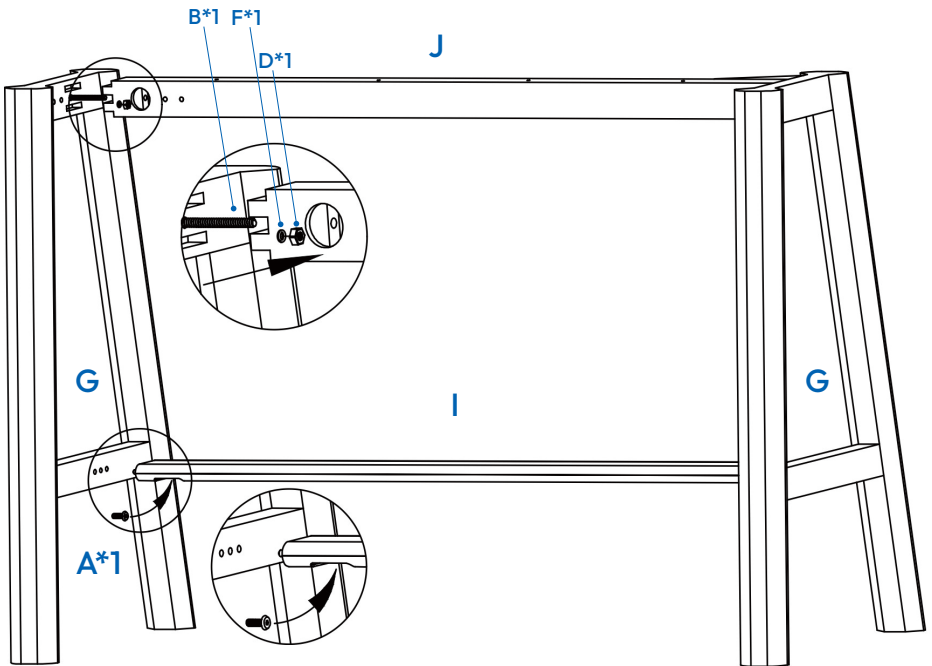

7

Take the other Bracket (L) and use four (A) screws to secure the Bracket (L) to the Beam (J) and Leg Frame (G). Tighten securely.

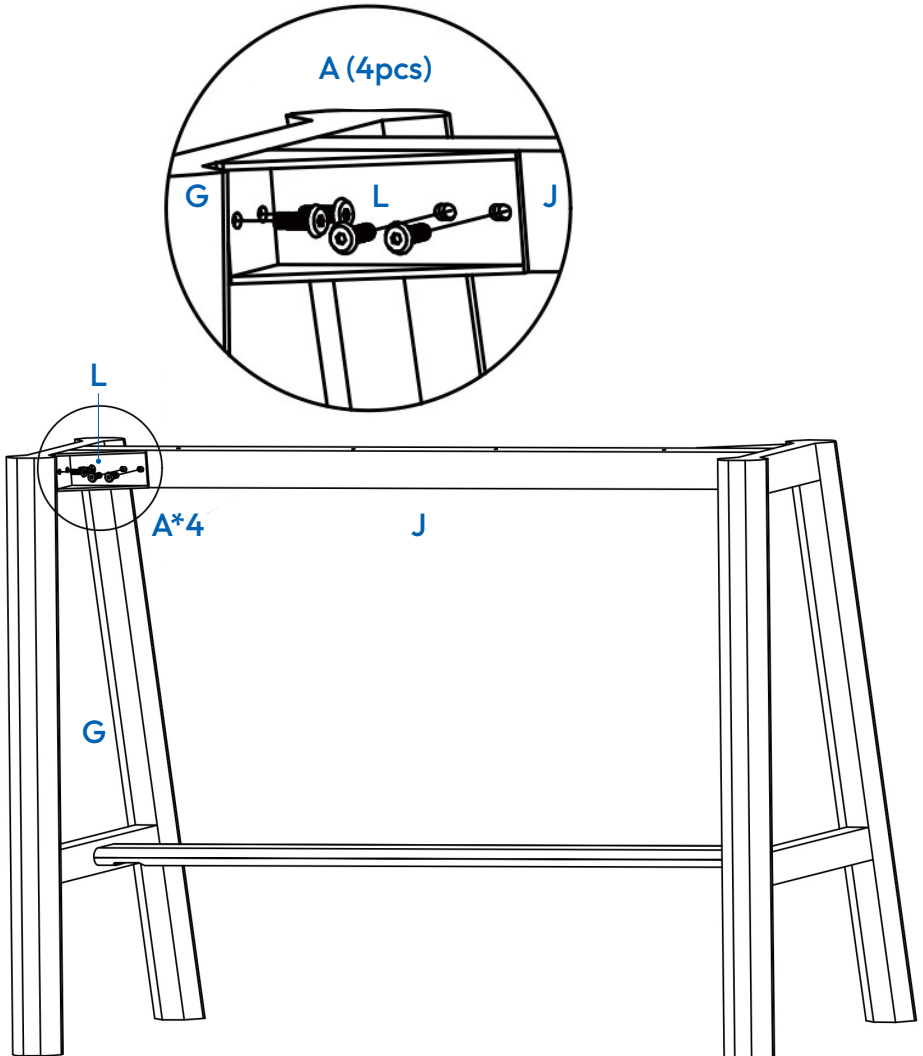

8

Clip on the Bracket Covers (K) to the Brackets (L) to conceal the inner construction.

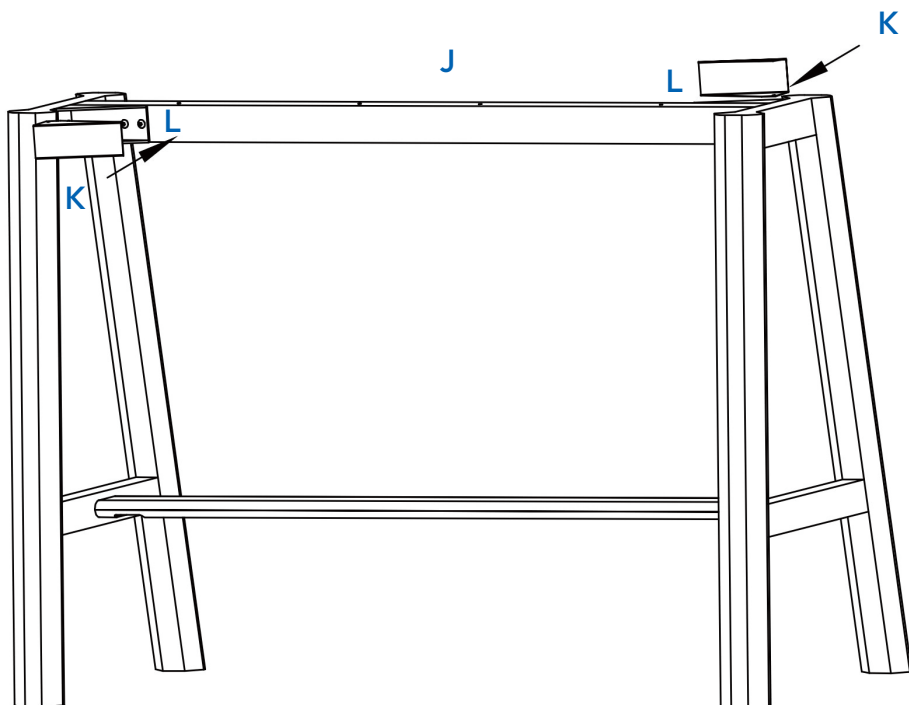

9

With the frame standing upright, place the Work Top (H) on the frame. Use eight (C) screws in total to fasten the Work Top to the Beam (J) and Leg Frames (G). Tighten all screws securely.

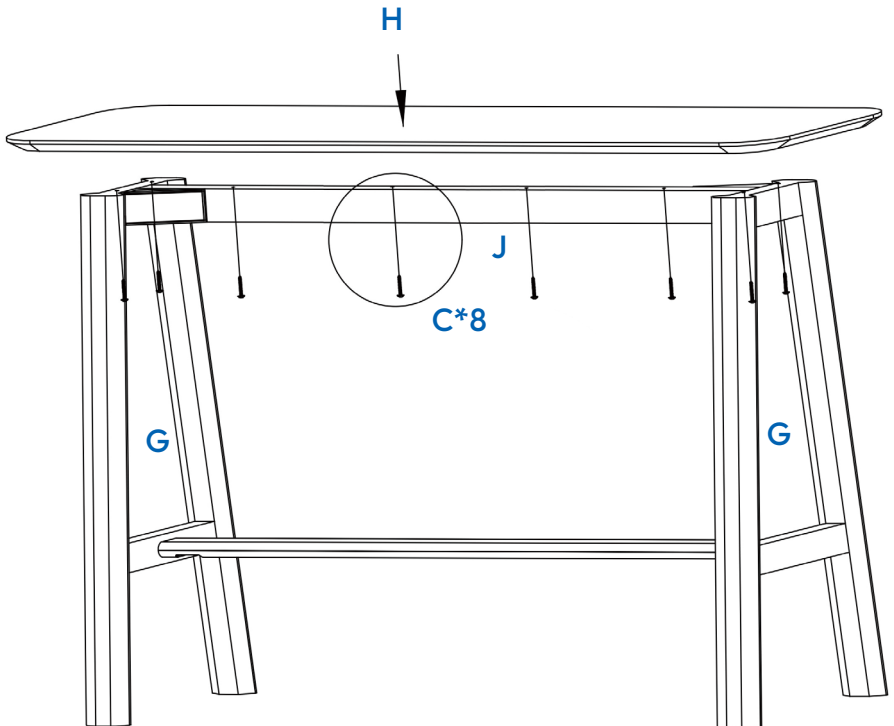

10 Put back the two small covers on the Foot Rail (I).

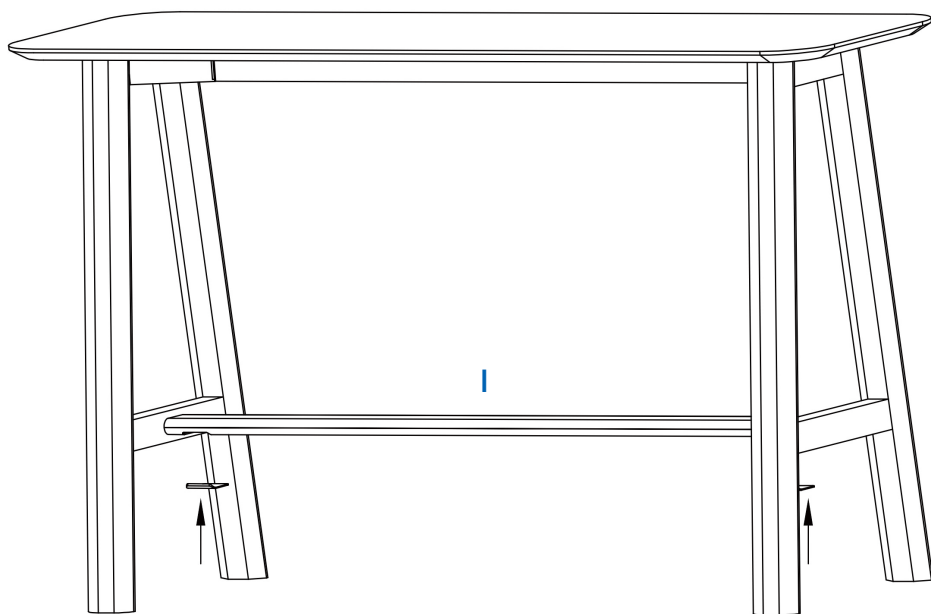

All done!

Nice work—you've just elevated your workspace with Friant Plus.

Now gather, create, and connect around your new table.

Care Instruction

1. Dust regularly with a soft cloth.
2. Avoid direct sunlight and excessive moisture.
3. Wipe spills immediately with a soft, dry cloth.

Fríant has everything you need to build your entire office.

For more than 30 years, Fríant has been creating high-quality office furniture to meet the needs of every workspace.

Made from the finest materials, our high-quality, durable, and stylish products are the building blocks of productivity.

Fríant Plus now brings our craftsmanship online, offering exclusive access to products not found in typical retail stores.

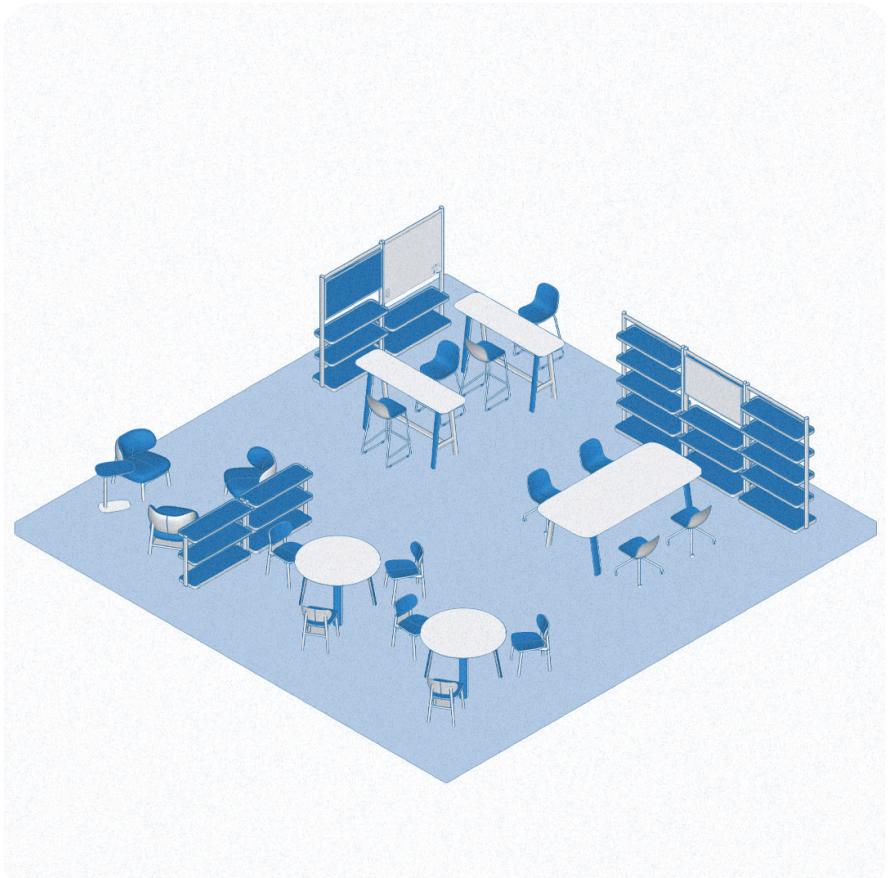



Contact

Have questions, comments, or need support?

Email: support@friantplus.com

Website: www.friantplus.com