

# 3-Tier Wooden Cabinet Shelf Stand

ASSEMBLY INSTRUCTIONS

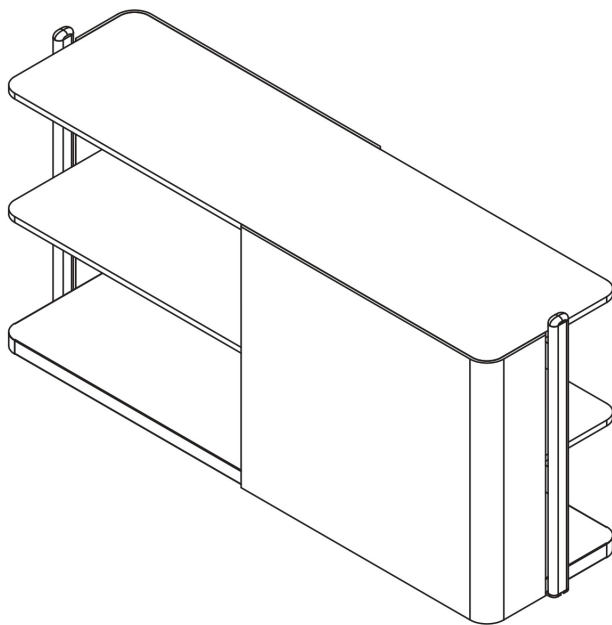

**FRIANT**

# Natural warmth meets organized design.

## Tools



(included)

Allen Key  
4 & 5mm **2 pcs**

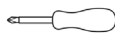

(not-included)











Phillips  
Head **1 pc**

Online  
Assembly  
Video





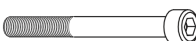



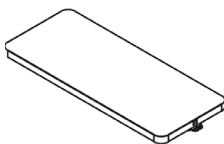

# Components

## Hardware

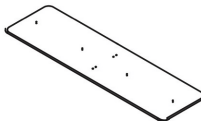
<b>A</b>		M6 10mm	16 pcs	<b>H</b>		Cam	6 pcs
<b>B</b>		M6 12mm	16 pcs	<b>I</b>		Wood Pin	6 pcs
<b>C</b>		M6 12mm	16 pcs	<b>J</b>		Cam Pin	6 pcs
<b>D</b>		M6 20mm	4 pcs	<b>K</b>		Cam Cap	6 pcs
<b>E</b>		M6 65mm	8 pcs				
<b>F</b>		ST4.2 16mm	16 pcs				
<b>G</b>		ST3 16mm	32 pcs				

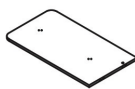
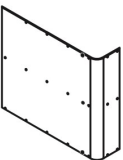
## Main Parts

				
<b>L</b> Base Shelf 1 pc	<b>M</b> Upright Post 2 pcs	<b>N</b> Shelf Support Bar 2 pcs	<b>O</b> Footing 4 pcs	
				
<b>P</b> Top Shelf 1 pc	<b>Q</b> Divider 1 pc	<b>R</b> Middle Shelf 2 pcs	<b>S</b> PET Surrounding 2 pcs	<b>T</b> PET Cap 24 pcs

# 1

Let's start with the base. Grab the Base Shelf (L), four Footings (O), and all (A) screws. Hold the Base Shelf (L) on its side and align the four holes on each Footing (O) with the plate on the underside of the Base Shelf (L). Insert (A) screws and tighten firmly. Repeat for the remaining three Footings (O).

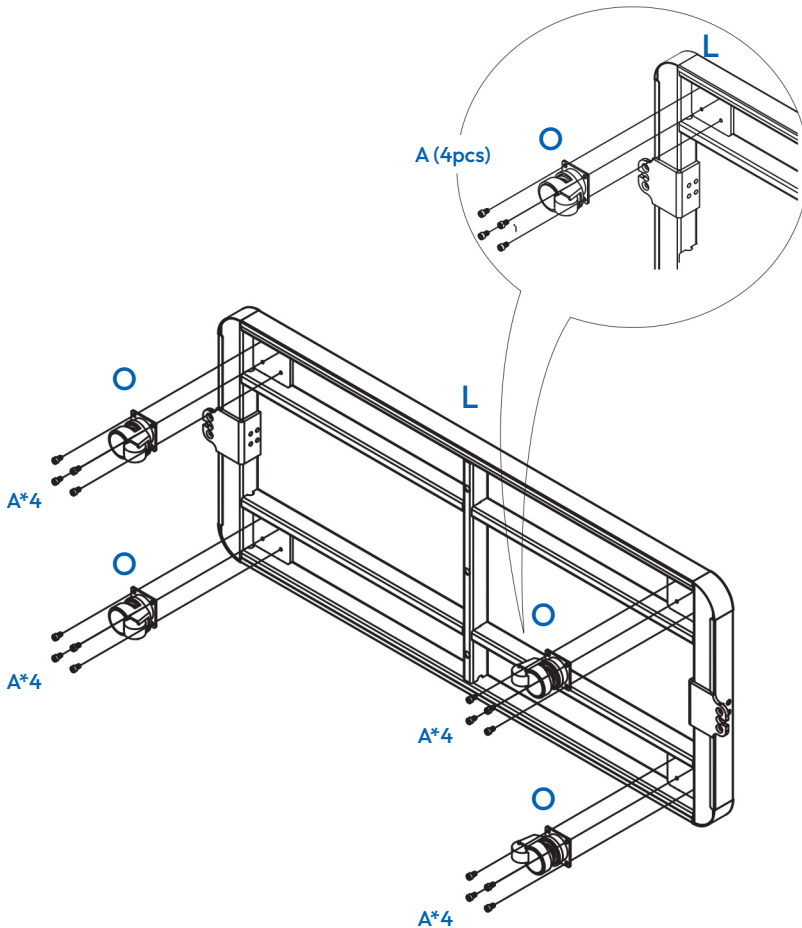

# 2

Now, let's build the frame. Grab one Upright Post (M) and lay it on the ground. Make sure the support points mirror each other. Then, align two Shelf Support Bars (N) with one Upright Post (M) and insert them together, pressing each end fully into place.

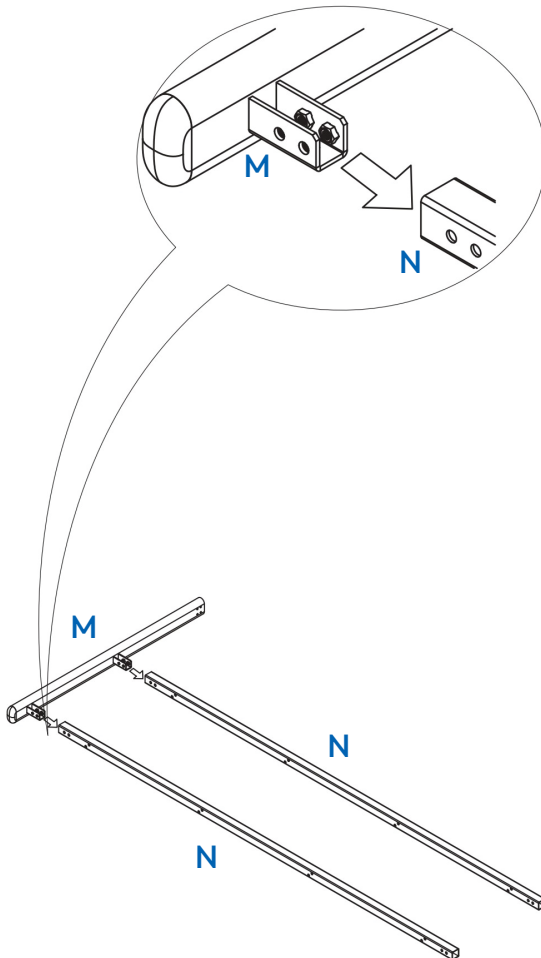

# 3

Ensure all bars are evenly seated on the ground before fastening them together. For each Shelf Support Bar (N), insert (C) screws to secure—two screws per side.

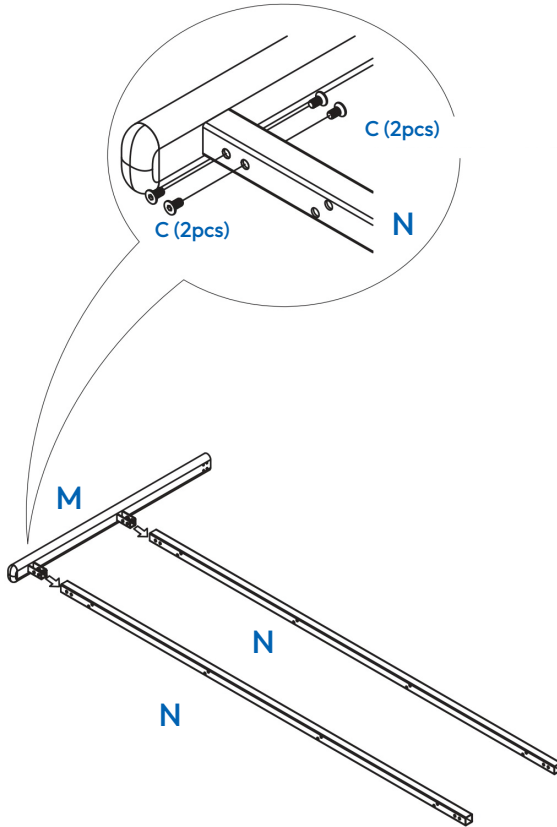

# 4

Bring the Base Shelf (L) back and align the half-assembled shelf frame with the upright plates on the Base Shelf (L).

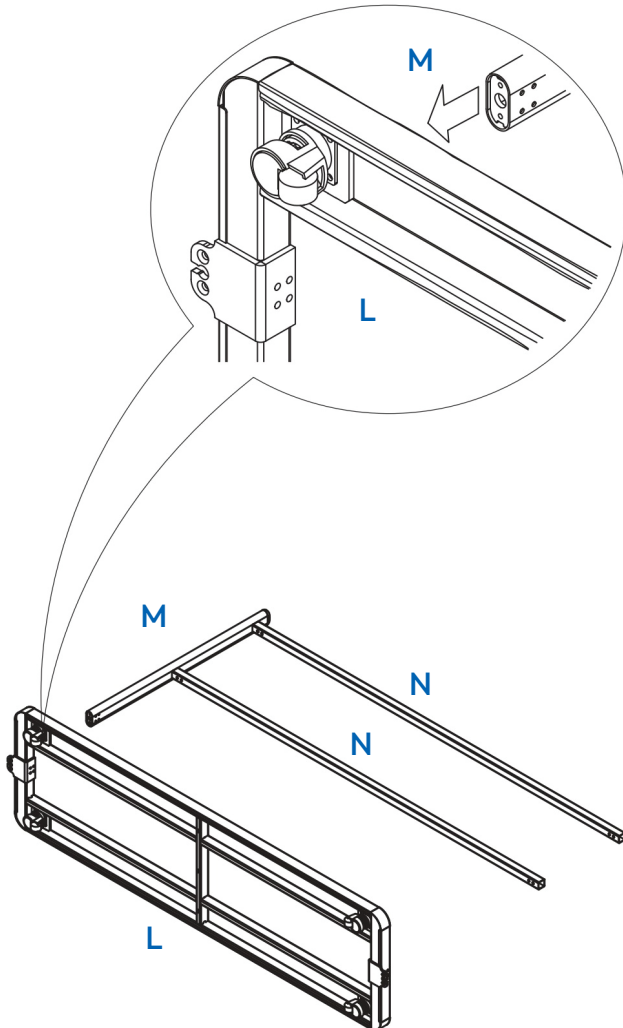

# 5

When the Upright Post (M) is aligned, insert two (D) screws into the bottom of the base plate. From the inner part of the base plate, insert and tighten four (E) screws firmly.

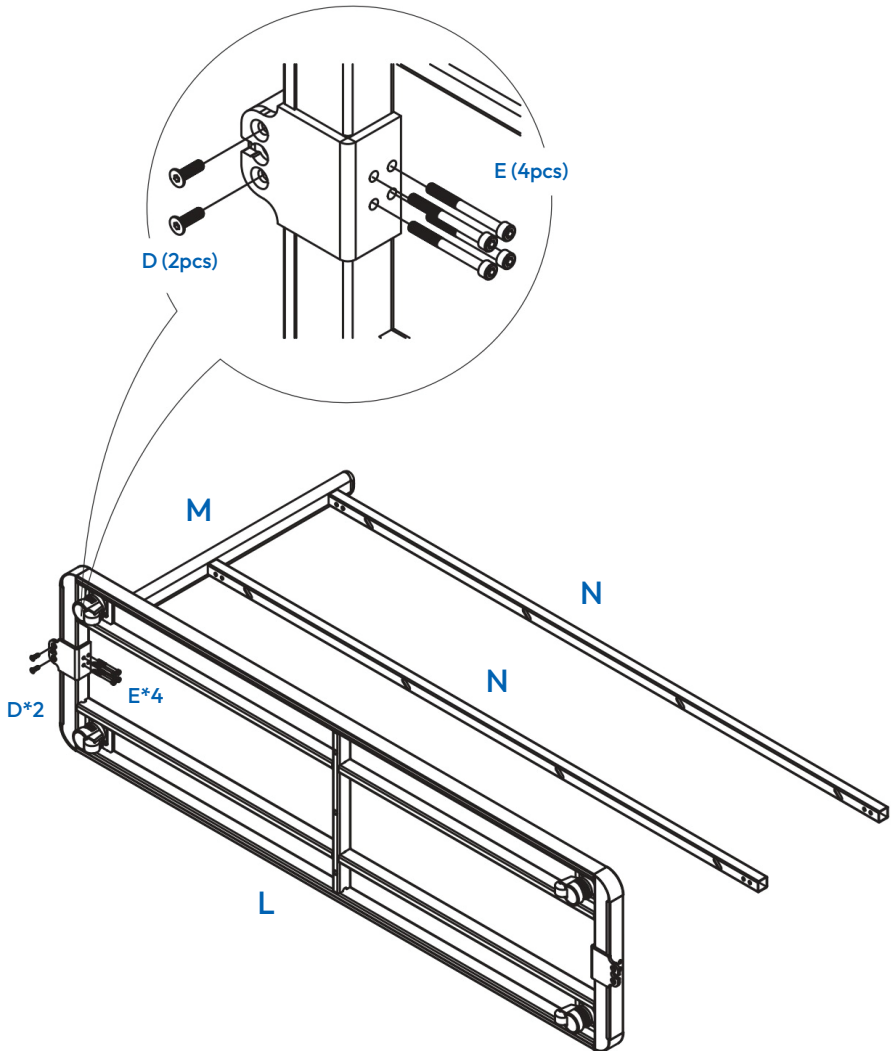

6

Pass the Divider (Q) through the two Shelf Support Bars (N).

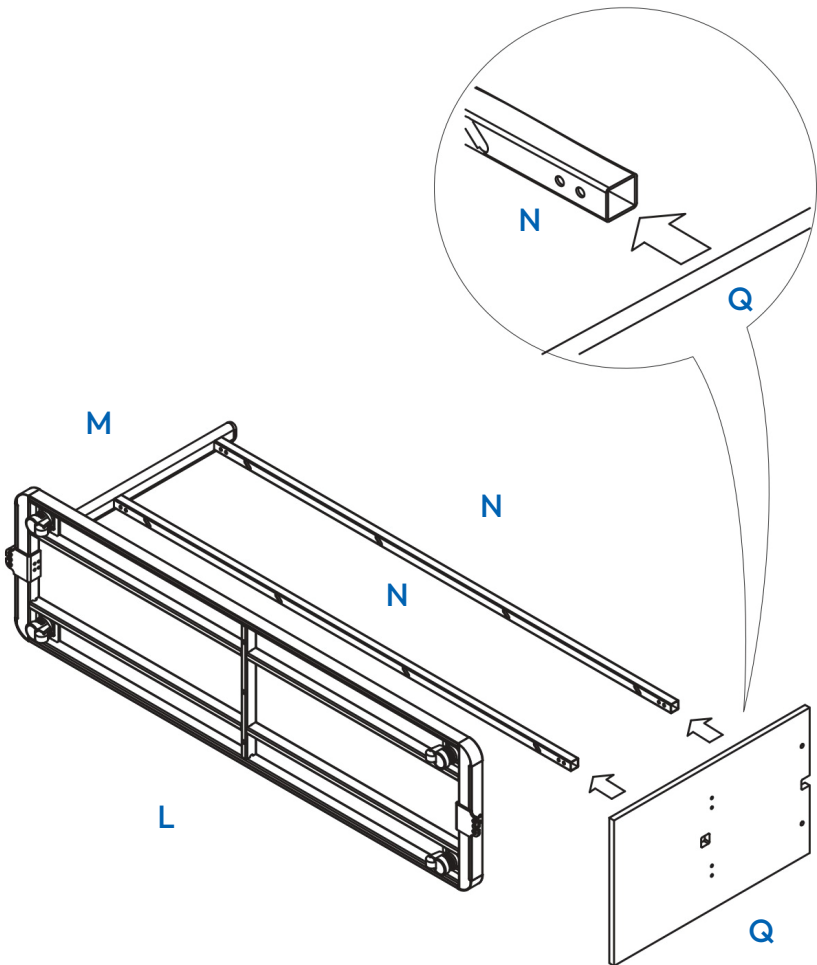

# 7

Bring the other Upright Post (M) and align it with the Shelf Support Bars (N), then insert them together fully.

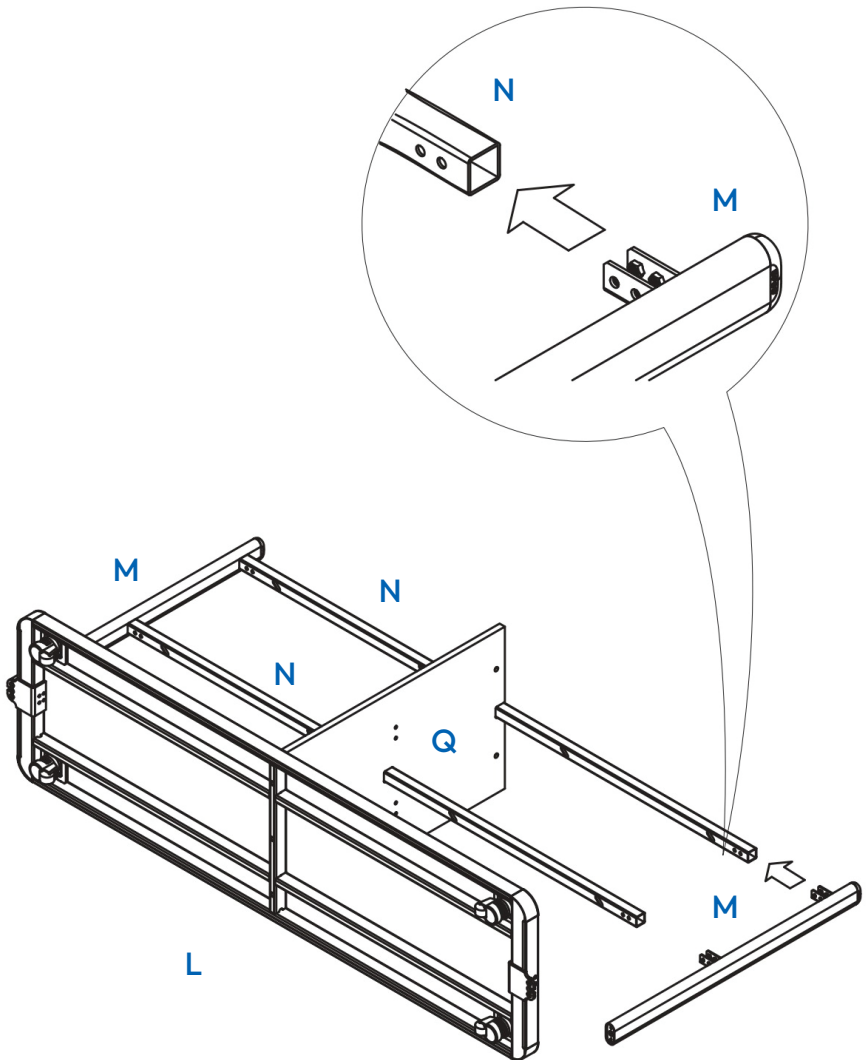

# 8

Fasten the structure. For each Shelf Support Bar (N), insert (C) screws to secure—two screws per side. Then insert two (D) screws into the bottom of the base plate, and from the inner side, insert and tighten four (E) screws firmly.

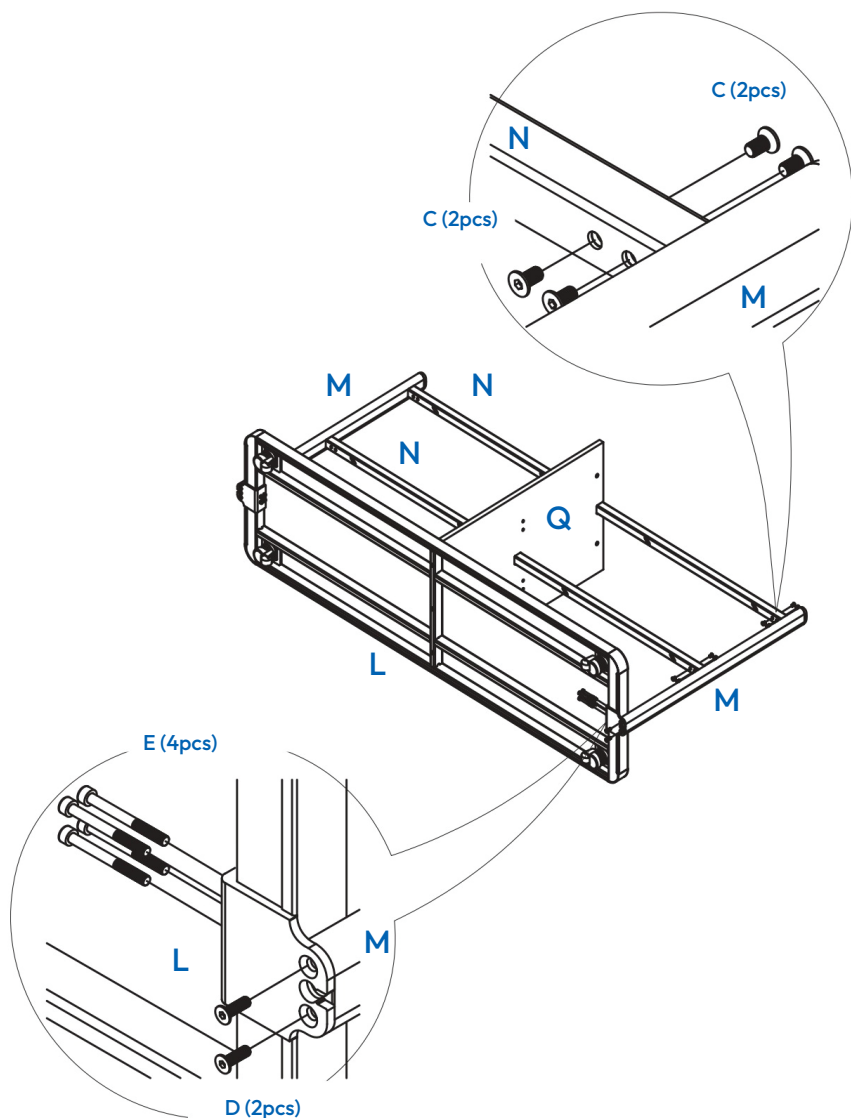

9

After confirming the frame and base are securely attached, carefully stand the entire piece upright.

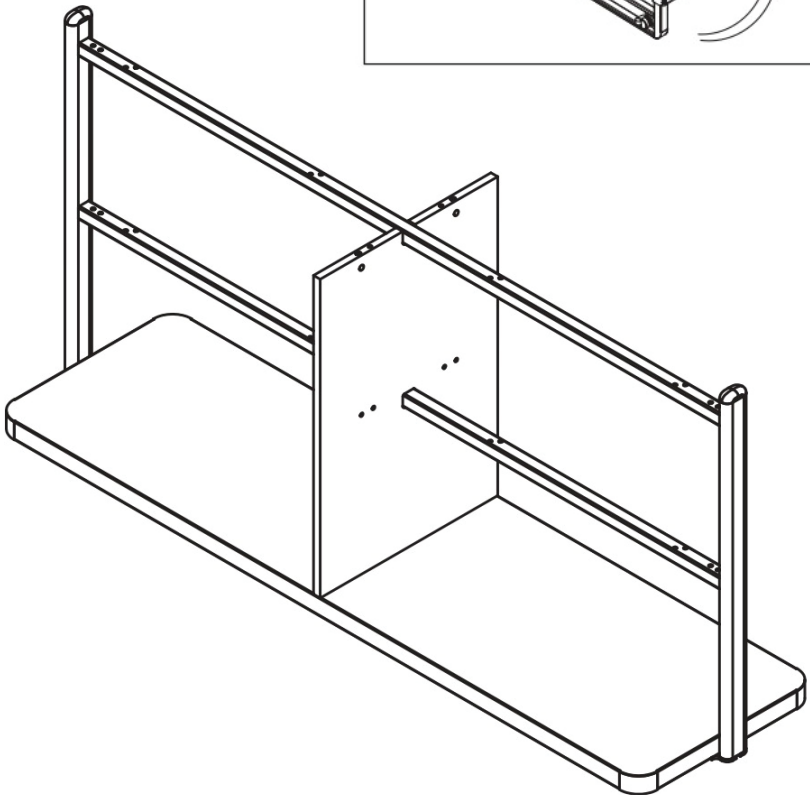
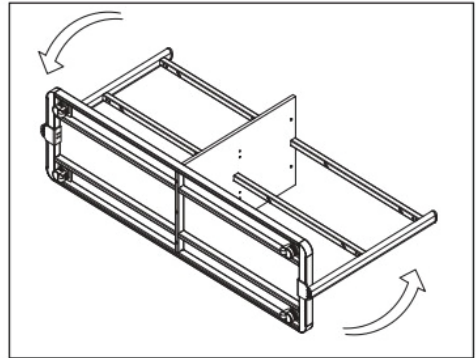

**10** Insert four (I) Wood Pins and four (J) Cam Pins into both sides of the Divider (Q). The Cam Pins should always be on the outside of the pair.

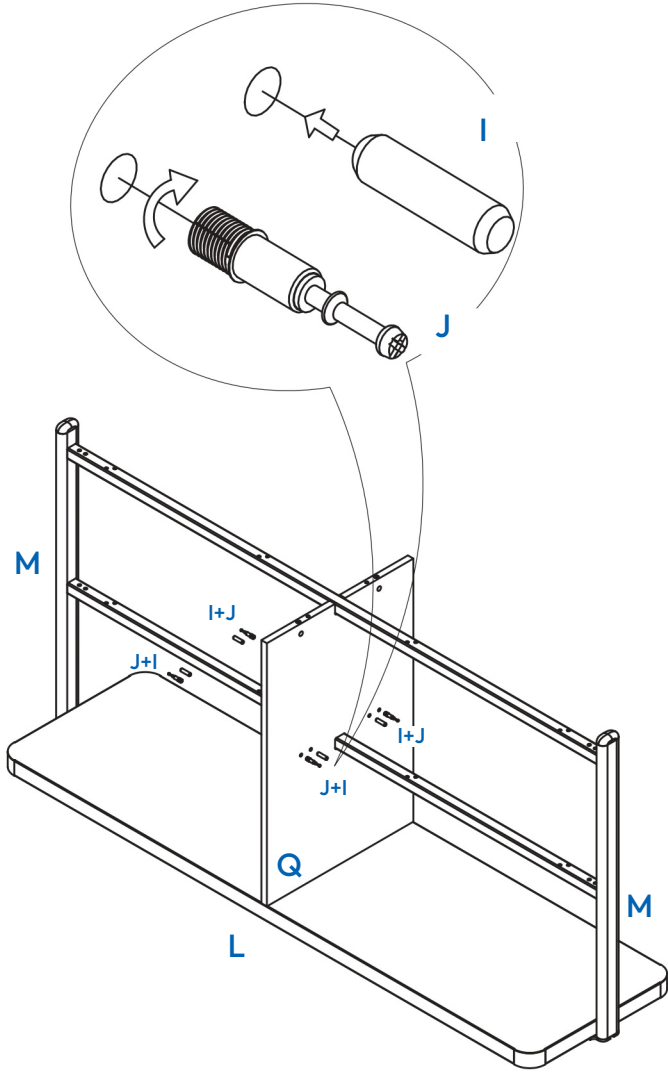

# 11

You will now slide the Middle Shelf (R) on the pins you just installed. Lift one end of the shelf, insert the (J) Cam Pin and (I) Wood Pin, then rest the other end flat onto the Shelf Support Bar (N). Repeat with the Middle Shelf on the other side.

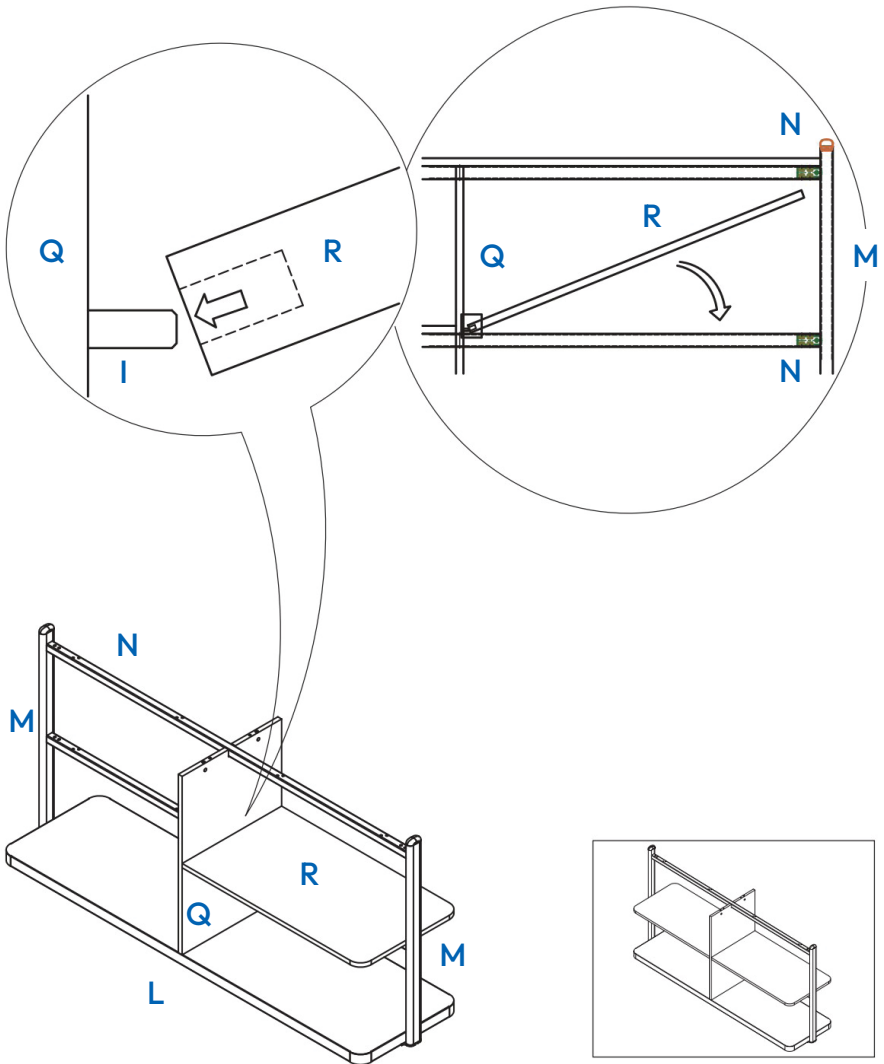

# 12

Now look under the Middle Shelf (R) you just placed, and insert two (H) Cams in the cam holes. Turn counter clockwise to secure. Repeat for the other Middle Shelf (R).

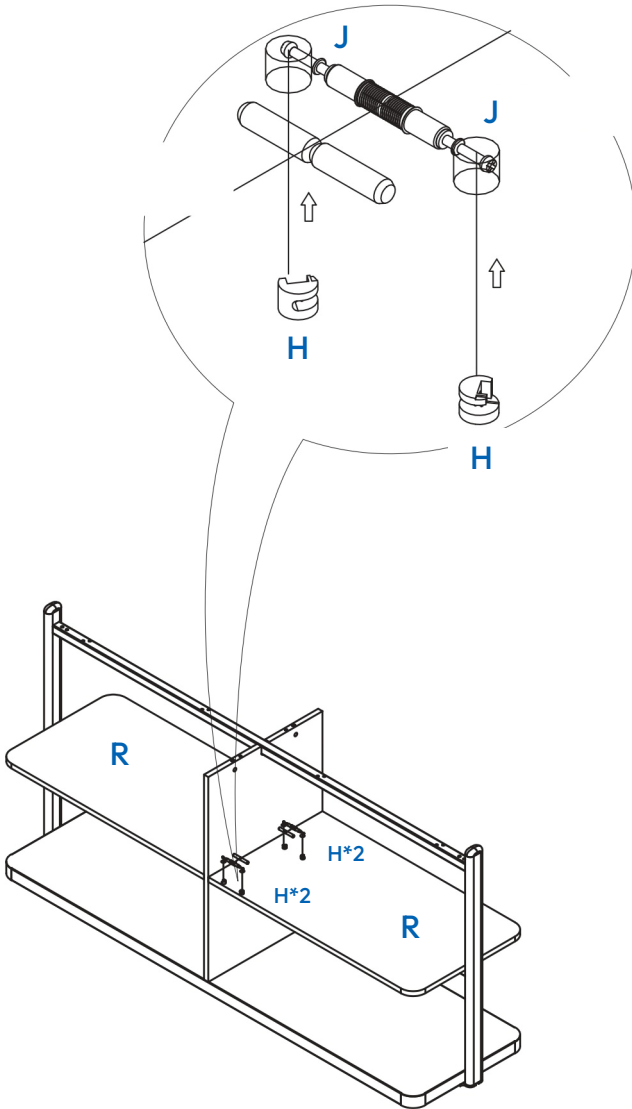

**13** Insert two (I) Wood Pins into the top of the Divider (Q). The Wood Pins go in the inner hole.

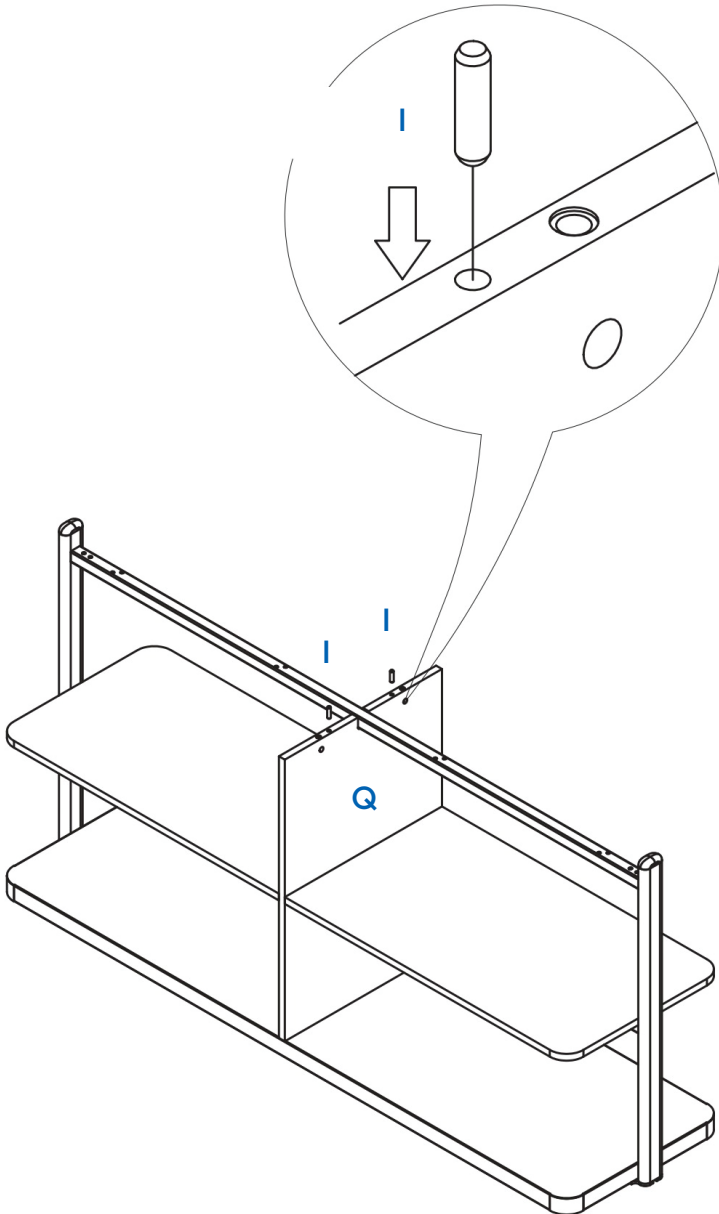

# 14

Insert two (J) Cam Pins into the underside of the Top Shelf (P). Cam Pins go in the outer holes.

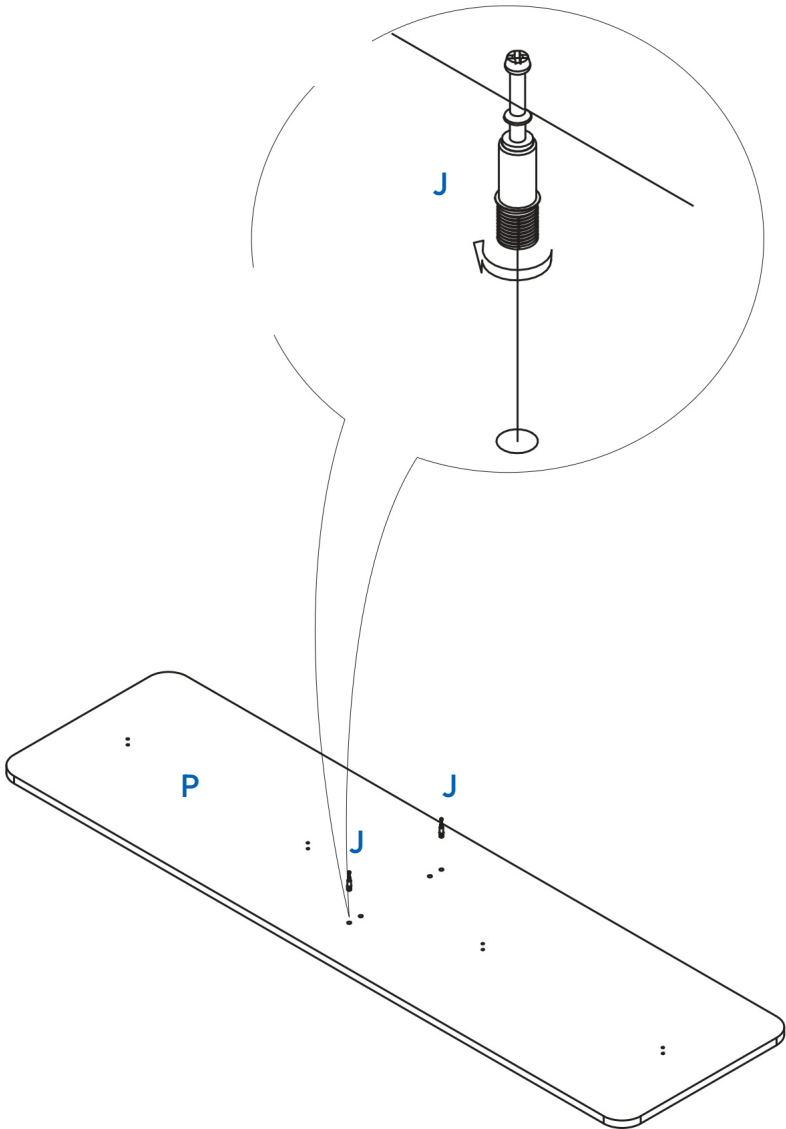

# 15

Flip the Top Shelf (P) with the top side facing up.

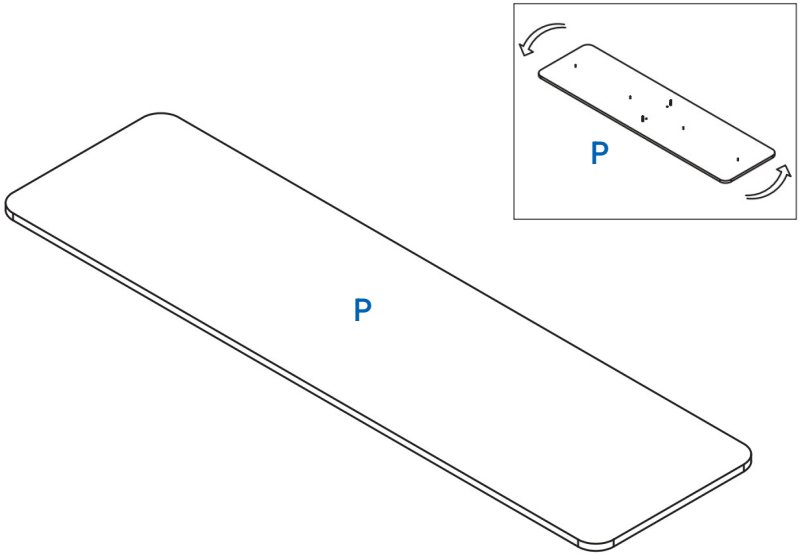

# 16

Insert (J) Cam Pins into the top holes of the Divider (Q). Insert (I) Wood Pins into the underside holes of the Top Shelf (P).

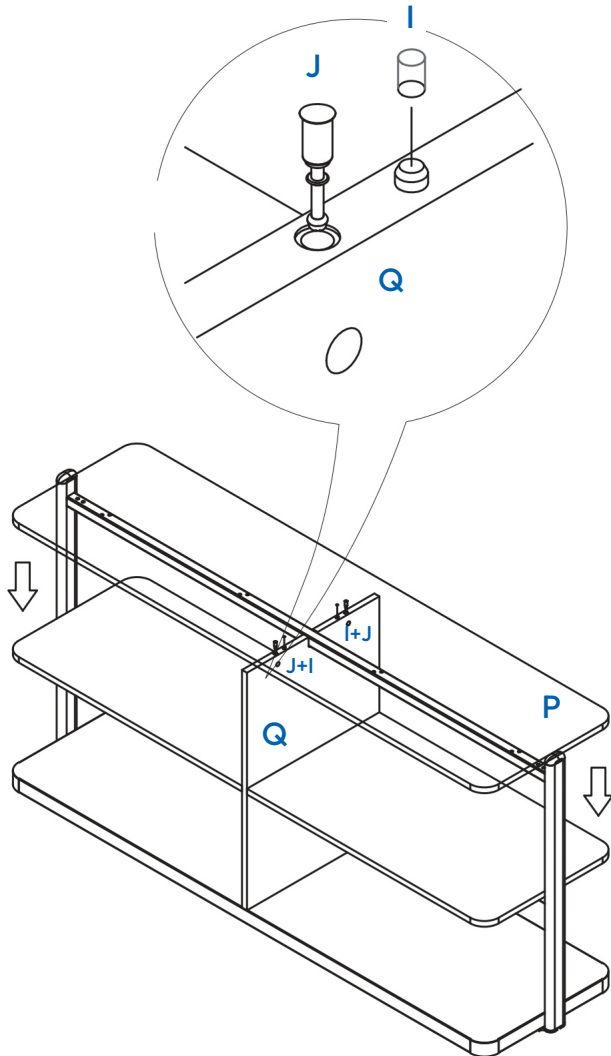

# 17

Insert two (H) Cams into the top of the Divider (Q) and secure them clockwise.

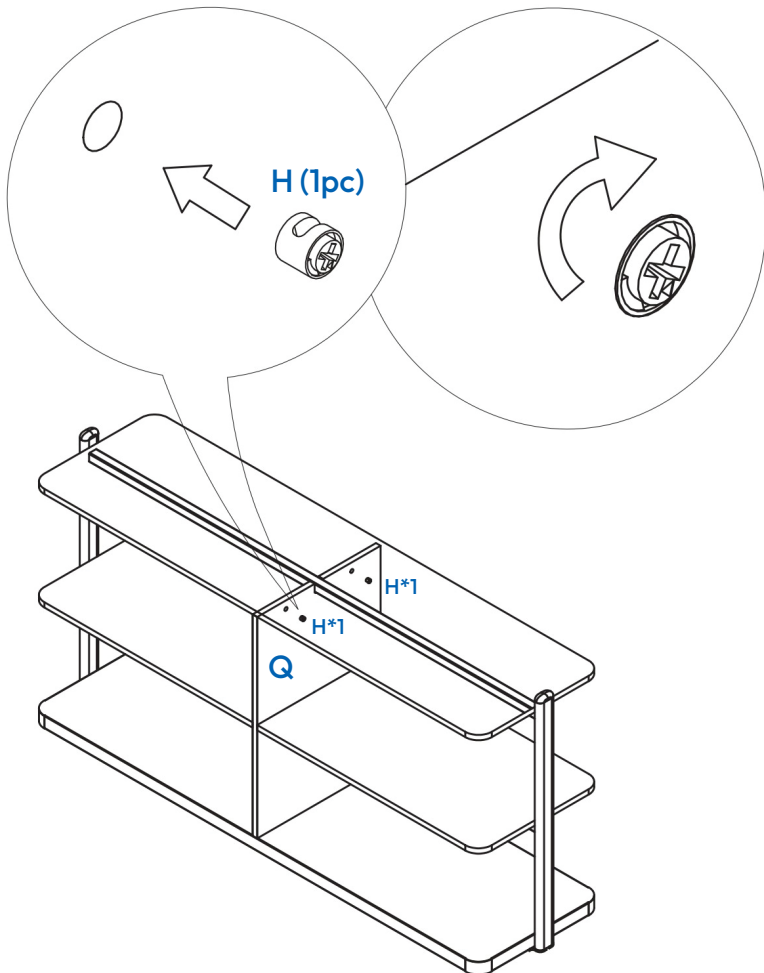

# 18

Each shelf attaches to the Shelf Support Bars (N) using pairs of (B) screws. Place each shelf on top of the bar, align the holes from beneath, then insert and tighten (B) screws. Repeat for a total of eight screws for each level.

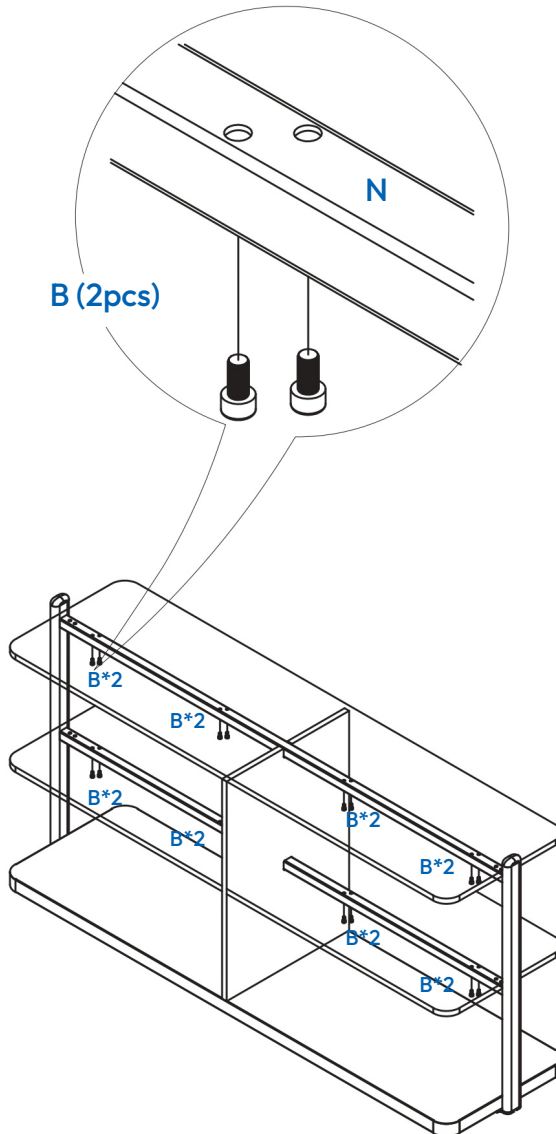

# 19

Insert six (K) Cam Caps into the holes of the (H) Cams.

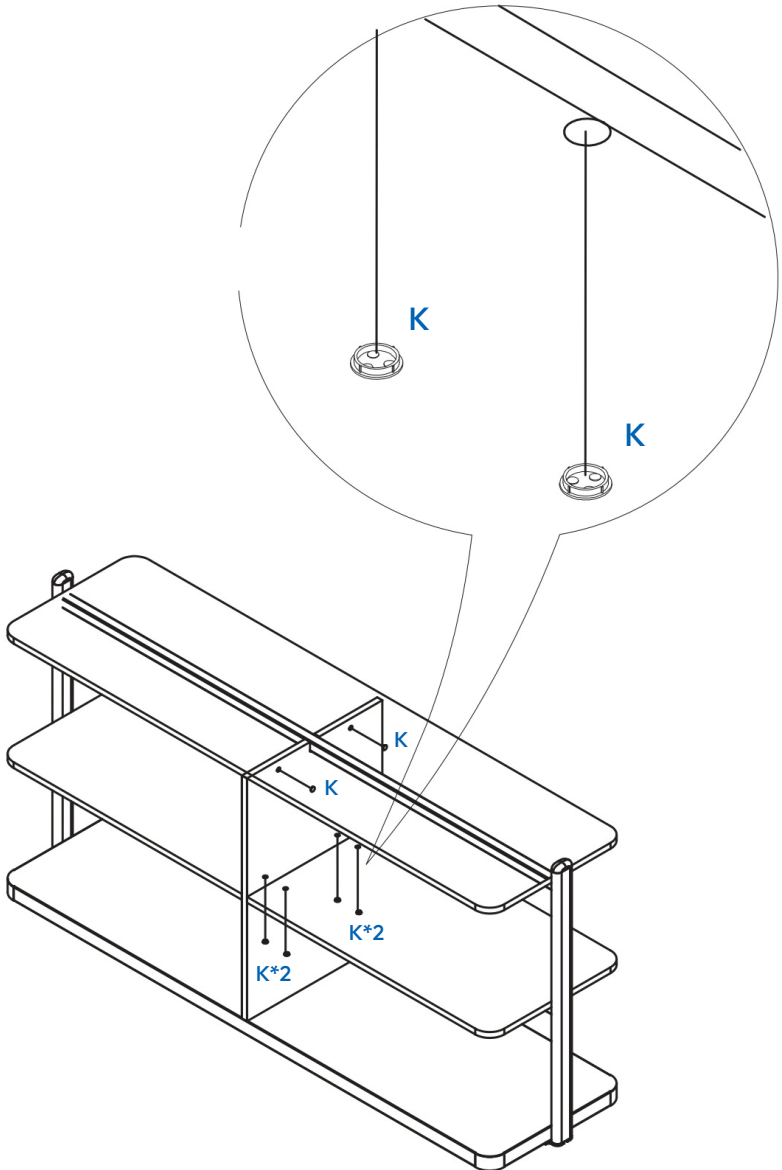

# 20

Align the PET Surroundings (S) along the edges of the Top Shelf (P), Middle Shelves (R), and Base Shelf (L). The other side needs to be installed in the opposite position.

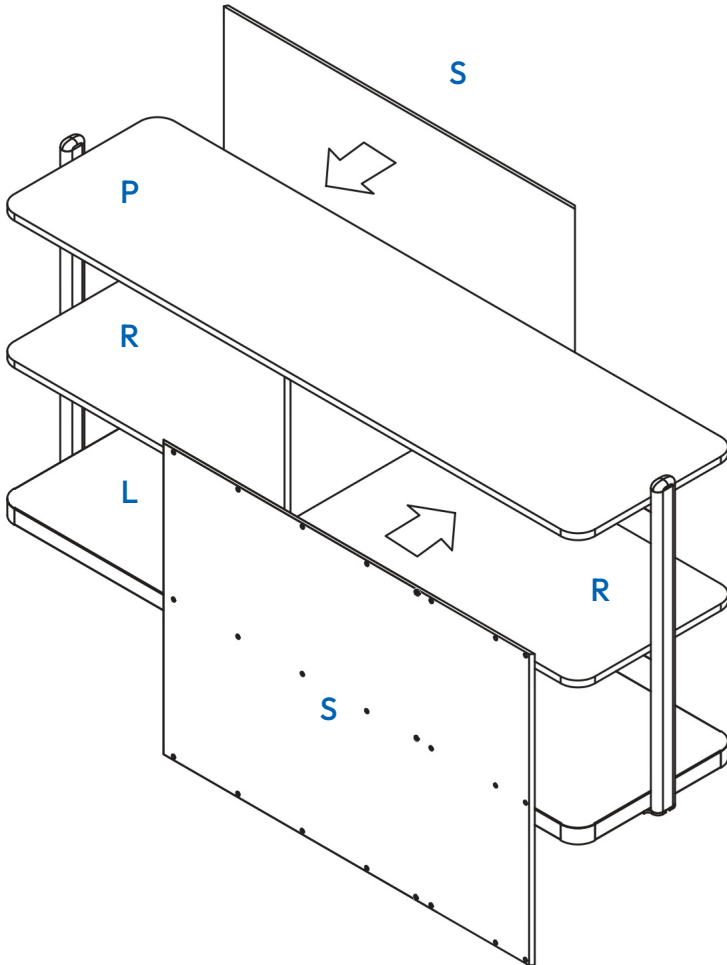

# 21

Gather all (F) and (G) screws. Secure the PET Surroundings (S) along the edges of the Top Shelf (P), Middle Shelves (R), and Base Shelf (L). For the Top Shelf (P) and Middle Shelves (R), use twelve (G) screws to secure. Repeat for the other side. For the Base Shelf (L), use six (F) screws to secure. Repeat for the other side.

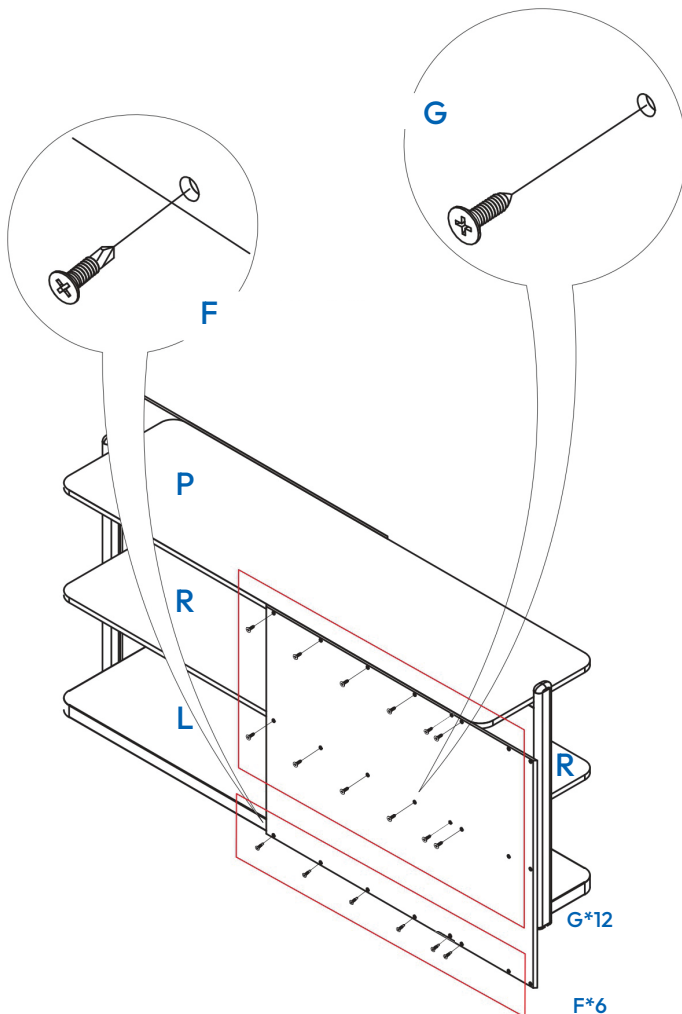

# 22

Gently bend the two PET Surroundings (S) to match the curvature of the shelves.

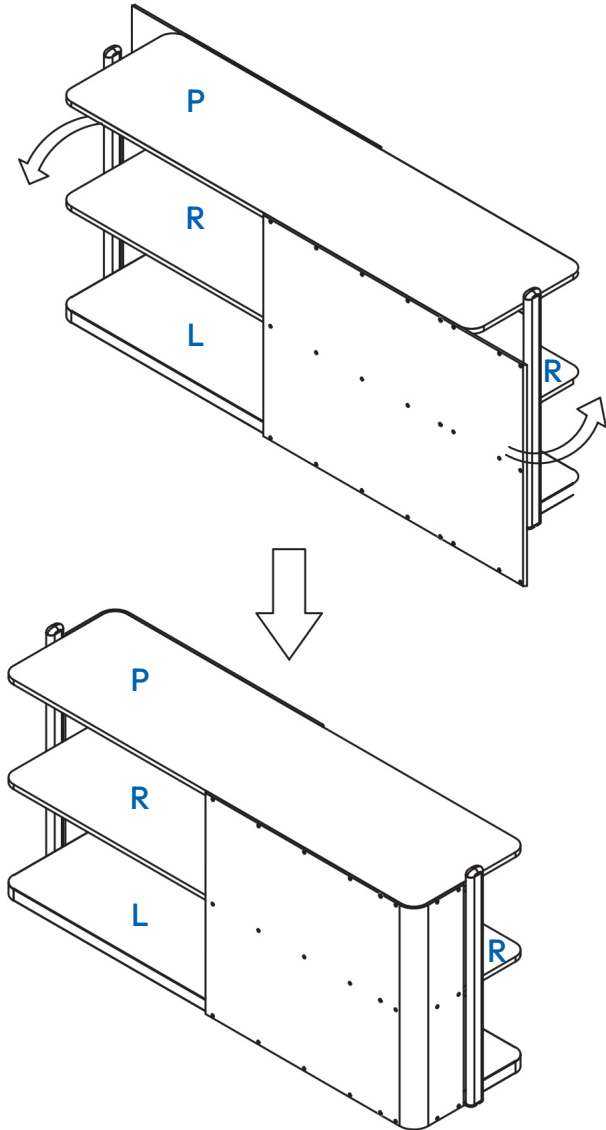

# 23

For the Top Shelf (P) and Middle Shelves (R), use four (G) screws to secure. For the Base Shelf (L), use two (F) screws to secure. Repeat for the other side.

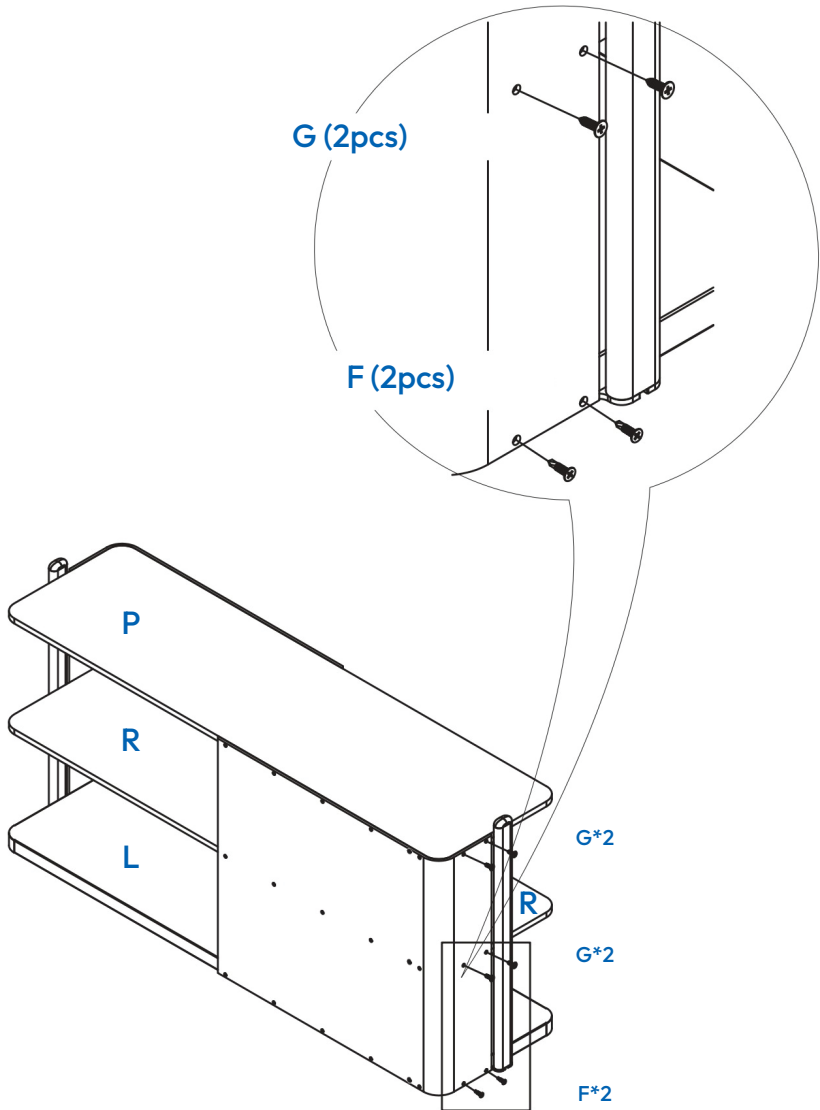

# 24

Split all twenty-four PET Caps (T) into two pieces each.

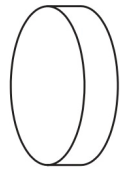
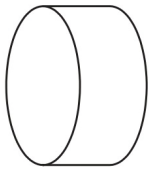

T (24pcs)

T (48pcs)

# 25

Press all forty-eight split PET Caps (T) into the screw holes on both PET Surroundings (S) to complete the assembly.

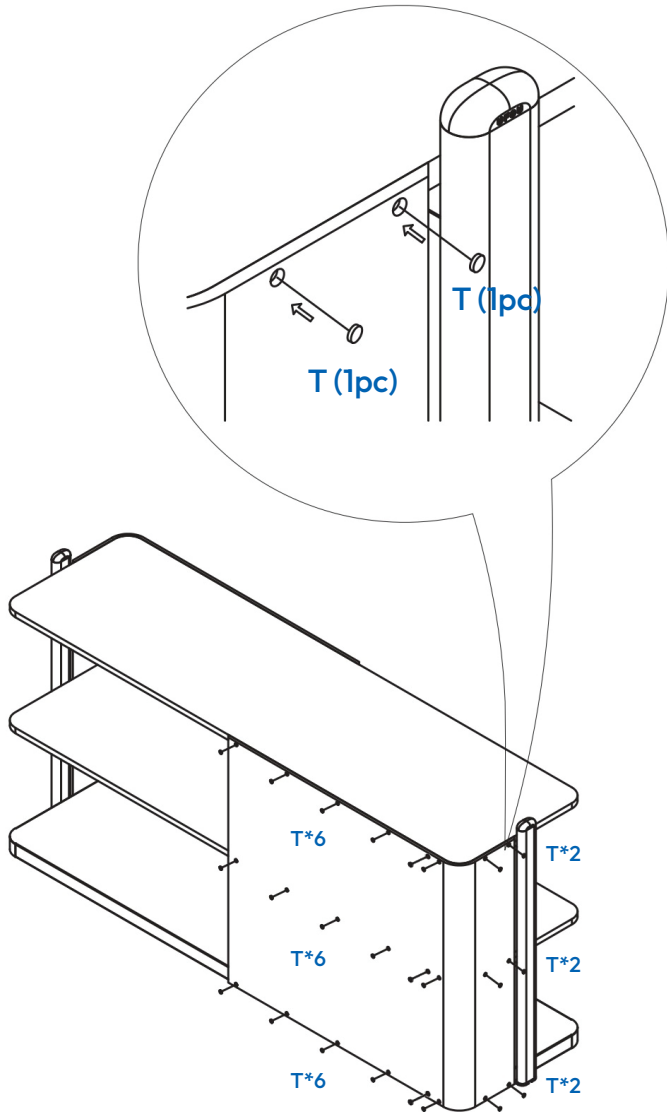

# All done!

Nice work—you've just elevated your workspace with Friant Plus.

Now organize, optimize, and enjoy the efficiency.

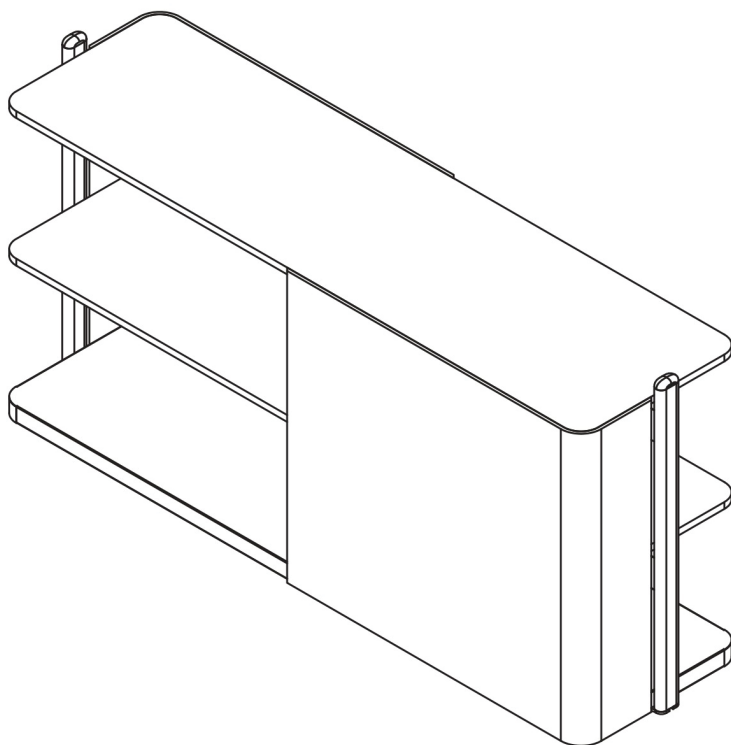

# Care Instruction

1. For oil stains on the particleboard shelves or powder-coated iron frame, gently wipe the surface with a soft cloth dampened with a mild detergent (such as warm soapy water).
2. Immediately dry with a clean, dry cloth after cleaning.
3. Avoid using strong chemical cleaners or abrasive tools to prevent surface damage.

# Friant has everything you need to build your entire office.

For more than 30 years, Friant has been creating high-quality office furniture to meet the needs of every workspace.

Made from the finest materials, our high-quality, durable, and stylish products are the building blocks of productivity.

Friant Plus now brings our craftsmanship online, offering exclusive access to products not found in typical retail stores.

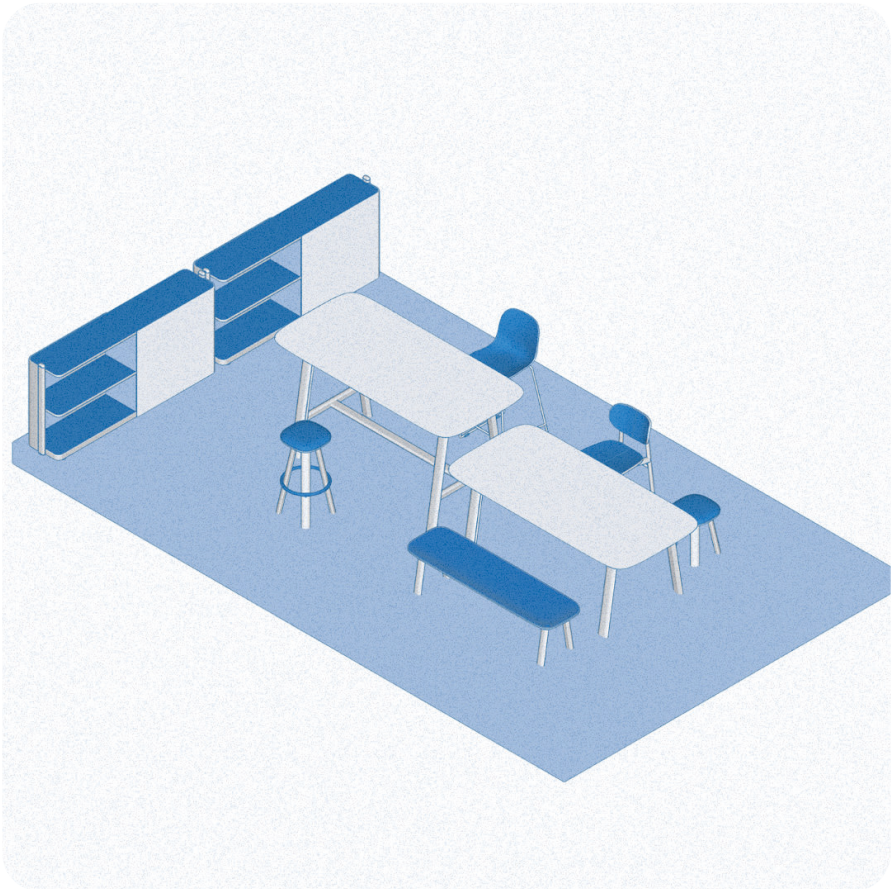



## Contact

Have questions, comments, or need support?

Email: [support@friantplus.com](mailto:support@friantplus.com)

Website: [www.friantplus.com](http://www.friantplus.com)